

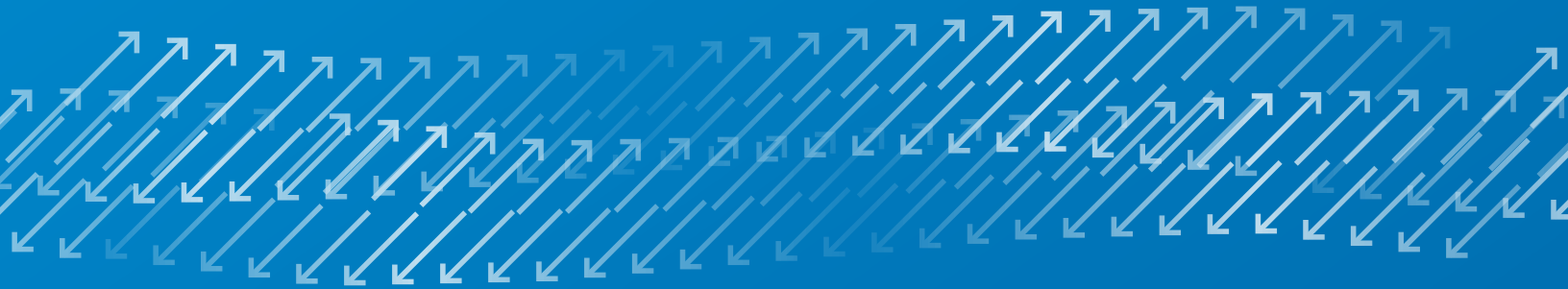

Model 680 High-Temperature Grips

Versatile, high-quality grips for testing up to 1500°C

PATENTED DESIGNS, AIRCRAFT-QUALITY CONSTRUCTION, AND THE ABILITY TO WITHSTAND EXTREMELY HIGH TEMPERATURES MAKE **MTS MODEL 680 HIGH-TEMPERATURE GRIPS** THE IDEAL CHOICE FOR TESTING AT ELEVATED TEMPERATURES.



Choosing a High-Temperature Grip

MTS Model 680 High-Temperature Grips provide accurate results for temperature-sensitive materials and minimize risk from thermal stress on your specimens.

MTS offers three high-temp grips, each designed for both fatigue and static testing at high temperatures. The Model 680.01 supports button-head and threaded end specimens at temperatures up to 1000°C.

The Model 680.10 is designed to accommodate flat, button-head and threaded end round specimens at temperatures up to 1000°C. The Model 680.15 is designed for temperatures up to 1500°C and can be used to conduct tests on flat, button-head and threaded end round specimens.

To choose the right MTS Model 680 High-Temperature Grip, focus on two main factors: the temperature range needed and the shape of the specimen.

If testing above 1000°C, use the Model 680.15. For flat specimens, either the Model 680.10 or 680.15 is suitable.

Benefits

- » Versatile fatigue and static testing at temperatures up to 1000°C (1832°F) or 1500°C (2700°F)
- » Options that work with flat and round (button-head end and threaded end) specimens

Material Testing Needs

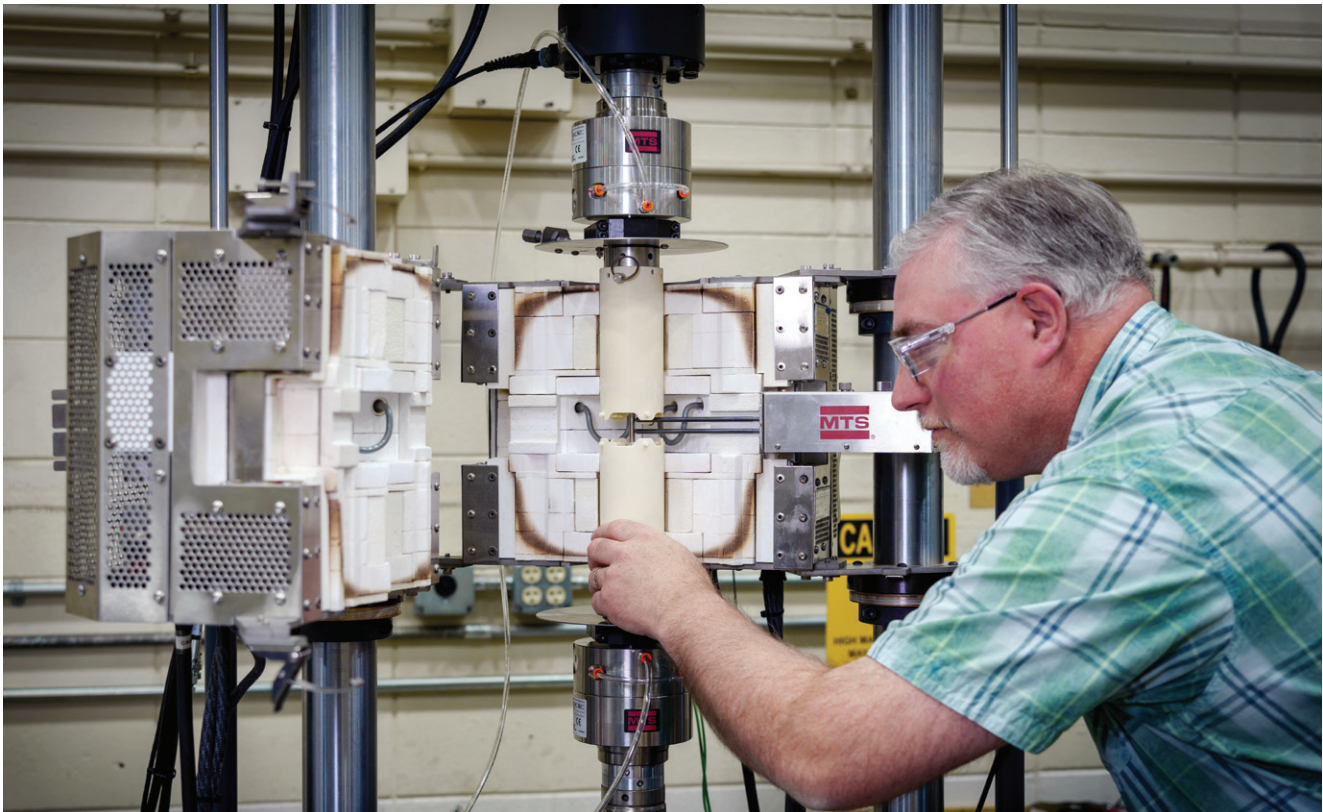
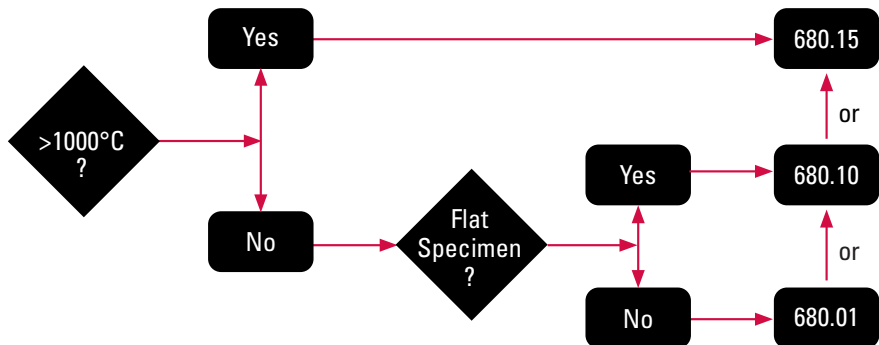

High-temperature testing solution with Model 680.15 grips and a 3-zone furnace

Model 680.01 High-Temperature Grips

Outstanding choice for LCF testing up to 1000°C

Overview

MTS 680.01 High-Temperature Grips are designed for low-cycle fatigue testing of round specimens at temperatures up to 1000°C (1832°F).

The water-cooled grip bodies, which reside outside the furnace, isolate hot parts of the grips from the actuator piston rod and from the load cell or other accessories. Hydraulic pressure, supplied to the grip bodies by the hydraulic hand pump, operates pistons which lock the specimen into place.

The required specimen adapters and extension rods are constructed of high-temperature superalloys that can extend into the heated zone of the furnace. Because the adapters and extension rods remain hot during testing, thermal gradients within the specimen are minimized.

High-Temperature Application

- » Low-cycle Fatigue Testing (including -1 R Ratio)
- » High-cycle Fatigue Testing (up to 5 Hz)
- » Creep Testing
- » Monotonic Testing

Required Accessories

These grips require button-head or threaded specimen adapters, a hydraulic hand pump and a water cooling kit.

Specifications	
Model Number	680.01B
Part Number	044-057-103
Force Rating	
» Ambient to 700°C (1292°F)	67 kN (15 kip)
» 700°C to 1000°C (1832°F)	8.9 kN (2.0 kip)
Weight (each)	9 kg (20 lb)
Insert Thread Size	M27x2 (1-14)

Note: Grip base ported for water cooling.

MTS recommends using the MTS 653.04 3-zone furnace for this grip application. Furnace selection is dependent on application requirements, specimen size.

Accessories

Type	Part Number
Hydraulic Hand Pump (Required)	100-254-832
Water Cooling Kit (Required)	057-697-502
Replacement Seal Kit	040-985-901



Hydraulic Hand Pump

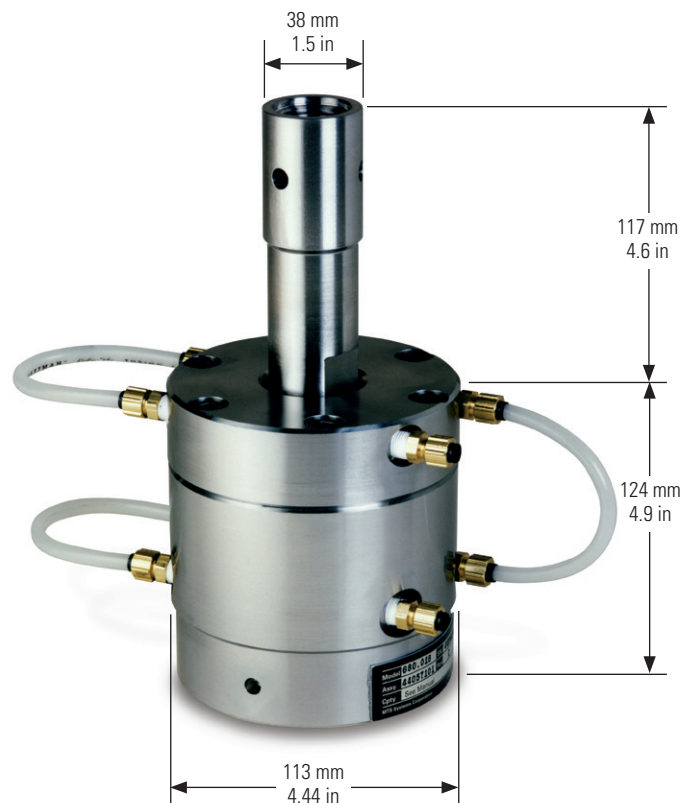

MTS 680.01 High-Temperature Grip

Button-Head End Round Specimens

Specimen Dimensions	Minimum	Maximum
A Overall Length	102 mm (4 in)	152 mm (6 in) *Recommended max.
B Maximum Button-Head Diameter*	–	20 mm (0.8 in)
C Maximum Button-Head Thickness	–	12.7 mm (0.5 in)
D Minimum Shank Length**	> 20 mm (0.8 in)	–
F Typical Gage Length	12.5 mm (0.5 in)	25 mm (1 in)

* Follow ASTM E606 for details on LCF specimen dimensions.

** Shank length depends on overall specimen dimensions and furnace hot zone dimensions.

Button-Head Inserts

Shank Diameter "G"	Part Number
6.35 mm (0.25 in)	041-901-902
10.16 mm (0.40 in)	041-901-904
12 mm (0.472 in)	041-901-903
12.70 mm (0.500 in)	041-901-901

Button-Head End Round Specimen

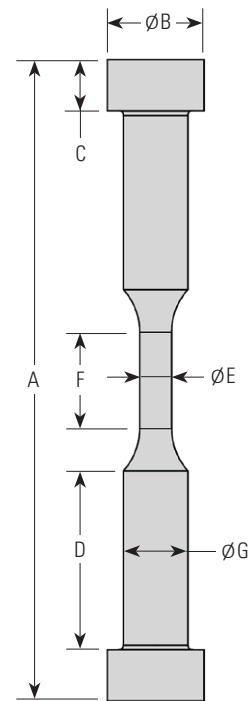

Threaded End Round Specimens

Specimen Dimensions	Minimum	Maximum
A Overall Length	102 mm (4 in)	152 mm (6 in)
F Typical Gage Length	12.5 mm (0.5 in)	25 mm (1 in)

Threaded Inserts

Thread "B"	Thread Gripping Length "C" *	Part Number
1/2-13 UNC-2B	28 mm (1.1 in)	041-901-801
M12 X 1.75	28 mm (1.1 in)	041-901-802
M16 X 2-6H	28 mm (1.1 in)	041-901-803
1/2-20 UNF-2B	28 mm (1.1 in)	041-901-804
M16 X 1-6H	28 mm (1.1 in)	041-901-805
M14 X 1-6H	28 mm (1.1 in)	041-901-806

* Follow ASTM E606 recommendations for specimen dimensions.

Threaded End Round Specimen

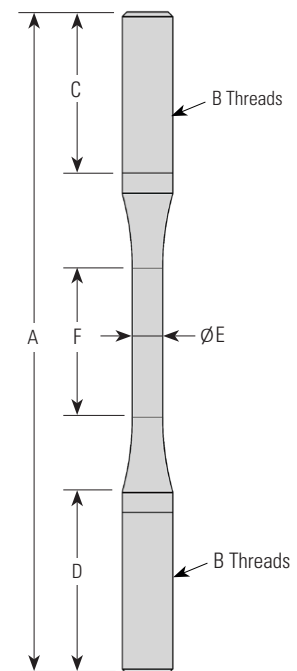

Model 680.10 & 680.15 High-Temperature Grips

Versatile grips for testing round and flat specimens

Overview

The MTS Model 680.10 High-Temperature Grip is designed to work with a three-zone high temperature furnace to test flat and round specimens at temperatures up to 1000°C in the specimen gage section. The Model 680.15 can be used to test up to 1500°C. These grips reduce data variability and system downtime when used in conjunction with our unique, three-zone furnace. This system repeatedly achieves:

- » Less than a 1% thermal gradient over the specimen gage length in accordance with ASTM E606
- » Less than 50 $\mu\epsilon$ bending strain caused by misalignment, meeting ASTM E1012 Class 5 and ISO 23788 for round specimens.

High-Temperature Testing of Flat Specimens

Gripping flat specimens is more difficult than gripping round (button-head end or threaded end) specimens, because flat specimen grips rely on friction forces instead of shear forces to hold the specimen in place.

MTS has found a way to react the higher forces that are needed when using friction to grip a flat specimen, and has used materials that have significant strength at temperatures up to 1500°C.

This patented grip design incorporates air cooling into the hot section of the grip, enabling grip components to remain at a lower temperature than the temperature of the specimen.

The double-ended piston allows fatigue loads to go through the piston which increases the grip durability and extends grip life.

Isothermal High-Temperature Applications

- » Low-cycle Fatigue Testing (including -1 R Ratio)
- » High-cycle Fatigue Testing (up to 5 Hz)
- » Creep Testing
- » Monotonic Testing

Recommended System Configuration

The MTS high-temperature testing solution requires the grips, a specially designed three-zone furnace and a high-temperature extensometer.

MTS recommends using these grips with an MTS Landmark® test system.

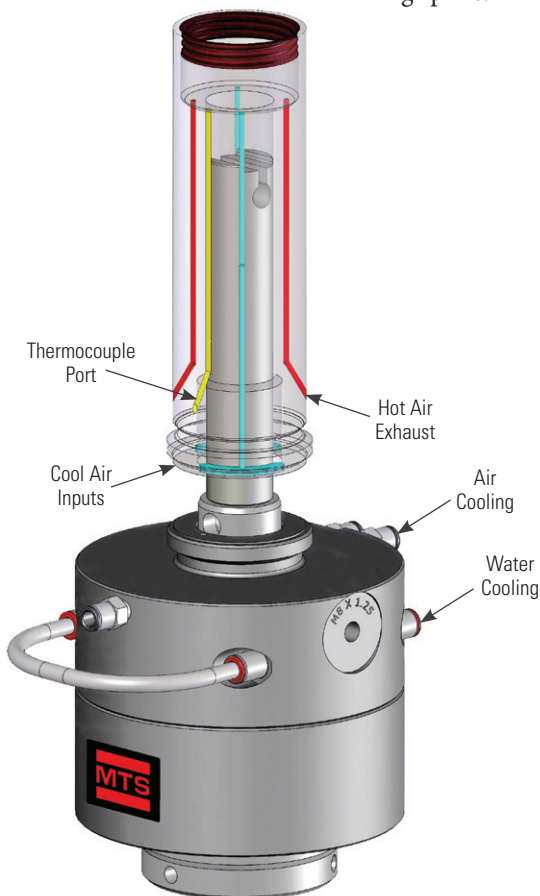

Model 680.10/15
Air or Inert Gas Cooling

Differences between Model 680.01 & 680.10

Although they look similar on the outside, the Model 680.10 1000°C High-Temperature Grip design is substantially different from the Model 680.01 grip internally.

- » The Model 680.10 1000°C High-Temperature Grip uses wedges, a wedge chamber, and active internal air or inert gas cooling. In addition, the hydraulic section is double acting.
- » The Model 680.01 Grip uses specimen inserts and the heated grip parts are not cooled. The hydraulic section is single acting.
- » The Model 680.10 can be used to test flat and round specimens, whereas the Model 680.01 is designed for round specimens only.

Single Grip Design Supports Multiple Specimen Types

Changing the grip components allows the same grip body to be used for different specimen geometries, eliminating the need for separate grips for each specimen type.

Ease of Changing Specimen Types

- » When changing between round specimen types, just need to change the inserts.
- » When changing between flat & round specimen types, need to change the push rod interface, chambers and inserts.
- » During any changes, the grip body, push rod, extension tube and collar remain the same.

Example of How to Change from Button-Head End to Flat Specimen on 680.15

1. Remove heat shield/clamp assembly
2. Remove collar, insert, chamber, extension tube and adapter piston
3. Slide flat wedges into teardrop slot on push rod
4. Reinstall extension tube and heat shield/clamp
5. Install wedge chamber and replace collar

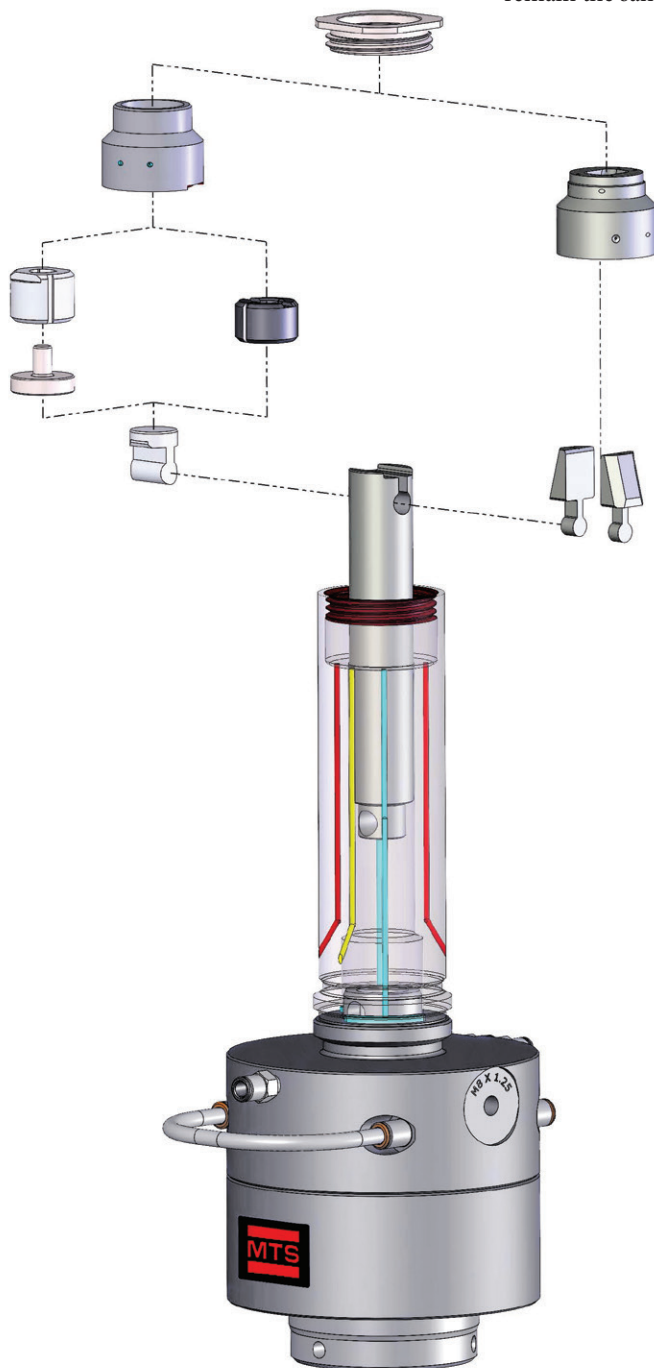

Grip Components

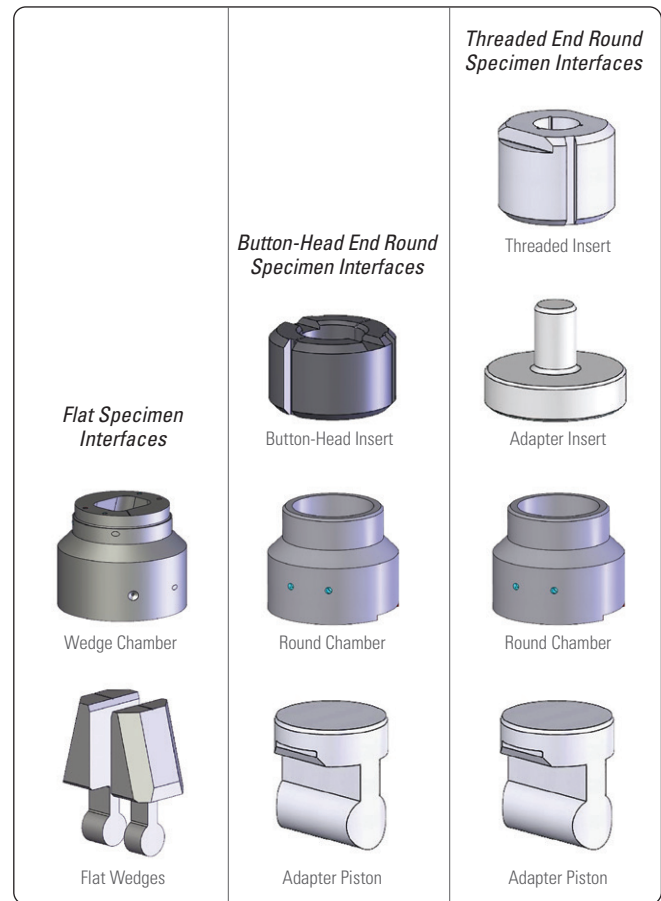

Model 680.10 1000°C High-Temperature Grips

Overview

The MTS Model 680.10 High-Temperature Grip is designed to work with a three-zone high temperature furnace to test flat and round specimens at temperatures up to 1000°C in the specimen gage section.

Specifications	
Model Number	680.10
Part Number	Configurable
Round Specimen Force Rating	
» Ambient to 700°C (1292°F)	25 kN (5.6 kip)
» 700°C to 1000°C (1832°F)	8.9 kN (2.0 kip)
Flat Specimen Force Rating	
» Ambient to 700°C (1292°F)	11 kN (2.5 kip)
» 700°C to 1000°C (1832°F)	5 kN (1.1 kip)
Temperature Rating	
» Maximum Specimen Temperature	1000°C (1832°F)
» Maximum Grip Temperature controlled to	850°C (1562°F)
Weight (each)	27 kg (60 lb)
Insert Thread Size	M27x2 (1-14)
Cooling Requirements	
» Grip base ported for water cooling	
» Grip extensions ported for air cooling	

MTS recommends using the specially designed three-zone furnace for this grip application. Furnace selection is dependent on application requirements, furnace bore size, specimen type and size.

Accessories

Type	Part Number
Hydraulic Hand Pump (2 are required: one for the upper grip & one for the lower grip)	100-254-831
Water Cooling Kit (Required)	057-697-511
Air Cooling Kit (Required)	100-306-565
Grip Extensions for flat, button-head end or threaded end round specimens	Configurable

Flat Specimens

Specimen Dimensions	Minimum	Maximum
A Overall Length	102 mm (4 in)	152 mm (6 in)
B Width	8 mm (0.32 in)	16 mm (0.63 in)
C Gripping Length	15.5 mm (0.61 in)	20 mm (0.79 in)
G Thickness	2.54 mm (0.1 in)	7.95 mm (0.313 in)
F Typical Gage Length	12.5 mm (0.5 in)	25 mm (1 in)

Flat Wedges*

Surface	Specimen Thickness "G"	Part Number
Surfallo	3.05 - 7.95 mm (0.120 - 0.313 in)	585808-01
Surfallo	0.0 - 5.59 mm (0.0 - 0.220 in)	585808-02
Surfallo	1.52 - 6.85 mm (0.060 - 0.270 in)	585808-03

* Usable Width: 8 - 16 mm (0.32 - 0.63 in);
Insertion Depth: 15.5 - 20 mm (0.61 - 0.79 in)

MTS 680.10 High-Temperature Grip

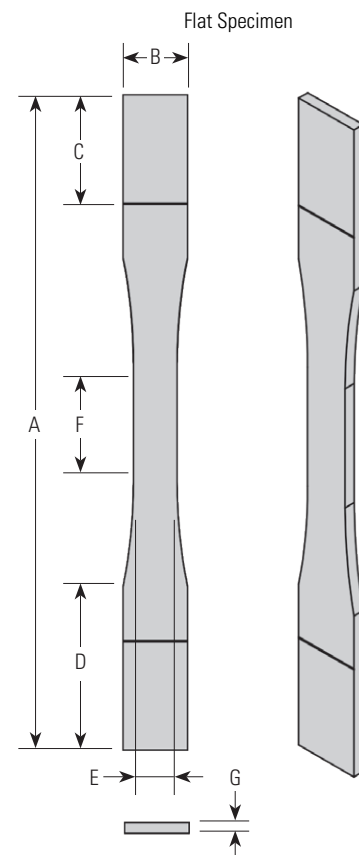

Button-Head End Round Specimens

Specimen Dimensions	Minimum	Maximum
A Overall Length	102 mm (4 in)	152 mm (6 in) *Recommended max.
B Maximum Button-Head Diameter*	–	20 mm (0.8 in)
C Maximum Button-Head Thickness	–	≤ 9.7 mm (0.38 in)
D Minimum Shank Length**	> 16 mm (0.63 in)	–
F Typical Gage Length	12.5 mm (0.5 in)	25 mm (1 in)

* Follow ASTM E606 for details on LCF specimen dimensions.

** Shank length depends on overall specimen dimensions and furnace hot zone dimensions.

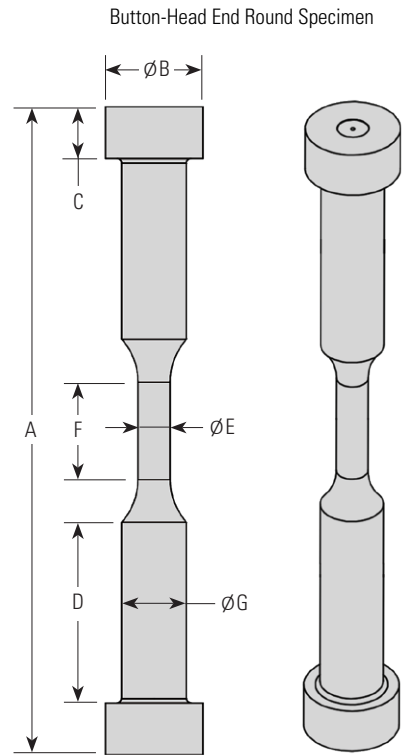

Button-Head Inserts

Shank Diameter "G"	Part Number
9.53 mm (0.375 in)	585811-01
10 mm (0.394 in)	585811-02
12 mm (0.472 in)	585811-03
12.70 mm (0.500 in)	585811-04

Threaded End Round Specimens

Specimen Dimensions	Minimum	Maximum
A Overall Length	102 mm (4 in)	152 mm (6 in)
F Typical Gage Length	12.5 mm (0.5 in)	25 mm (1 in)

Threaded Inserts

Thread "B"	Thread Specimen Length "C"	Part Number
M6 X 1.00 - 6H	> 8.97 mm (.353 in)	585809-01
1/4-20 UNC-2B	> 8.97 mm (.353 in)	585809-02
M8 X 1.25 - 6H	> 10.80 Mm (.425 in)	585809-03
5/16-18 UNC-2B	> 10.80 Mm (.425 in)	585809-04
M10 X 1.50 - 6H	> 14.12 mm (.556 in)	585809-05
3/8-16 UNC-2B	> 14.12 mm (.556 in)	585809-06
M12 X 1.75 - 6H	> 17.30 mm (.681 in)	585809-07
1/2-13 UNC-2B	> 17.30 mm (.681 in)	585809-08
M16 X 2.00 - 6H	> 18.08 mm (.712 in)	585809-09
5/8-11 UNC-2B	> 18.08 mm (.712 in)	585809-10
1/2-20 UNF-2B	> 17.30 mm (.681 in)	585809-11

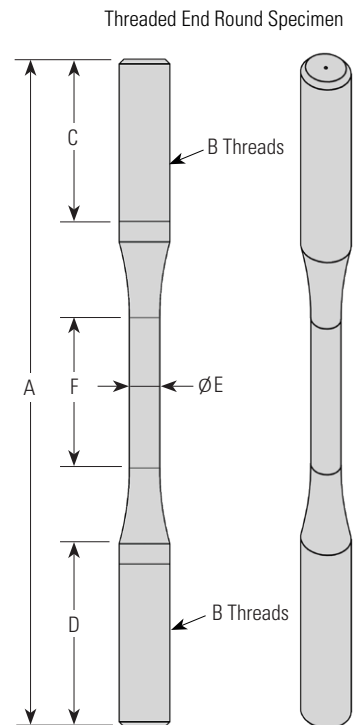

Model 680.15 1500°C High-Temperature Grips

Excellent choice for testing up to 1500°C

Overview

The MTS Model 680.15 High-Temperature Grip is designed to work with a specially designed three-zone furnace and a high-temperature extensometer to test flat and round specimens at temperatures up to 1500°C in the specimen gage section.

Specifications	
Model Number	680.15
Part Number	Configurable
Force Rating	
» Ambient to 700°C (1292°F)	25 kN (5.6 kip)
» 700°C to 1000°C (1832°F)	8.9 kN (2.0 kip)
Temperature Rating	
» Maximum Specimen Temperature	1500°C (2732°F)
» Maximum Grip Temperature controlled to	850°C (1562°F)
Weight (each)	29 kg (63 lb)
Insert Thread Size	M27x2 (1-14)
Cooling Requirements	
» Grip base ported for water cooling	
» Grip extensions ported for air cooling	

MTS recommends using the specially designed three-zone furnace for this grip application. Furnace selection is dependent on application requirements, furnace bore size, specimen type and size.

Accessories

Type	Part Number
Hydraulic Hand Pump (2 are required: one for the upper grip & one for the lower grip)	100-254-831
Water Cooling Kit (Required)	057-697-511
Air Cooling Kit (Required)	100-306-565
Grip Extensions for flat, button-head end or threaded end round specimens	Configurable

Flat Specimens

Specimen Dimensions	Minimum	Maximum
A Overall Length	108 mm (4.25 in)	152 mm (6 in) *Recommended max.
B Width	8 mm (0.32 in)	15 mm (0.59 in)
C Gripping Length	13.5 mm (0.53 in)	20 mm (0.812 in)
G Thickness	2.54 mm (0.1 in)	6.35 mm (0.25 in)
F Typical Gage Length	12.5 mm (0.5 in)	25 mm (1 in)

Flat Wedges*

Surface	Specimen Thickness "G"	Part Number
Surfallo	0.0 - 4.78 mm (0.0 - 0.188 in)	585807-01
Surfallo	2.03 - 6.35 mm (0.08 - 0.250 in)	585807-02

* Usable Width: 8 - 15 mm (0.32 - 0.59 in);
Insertion Depth: 13.5 - 20 mm (0.53 - 0.812 in)

MTS 1500°C High-Temperature Grip

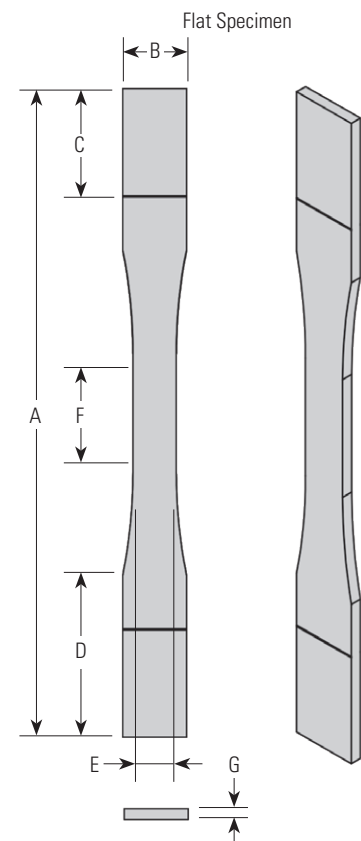
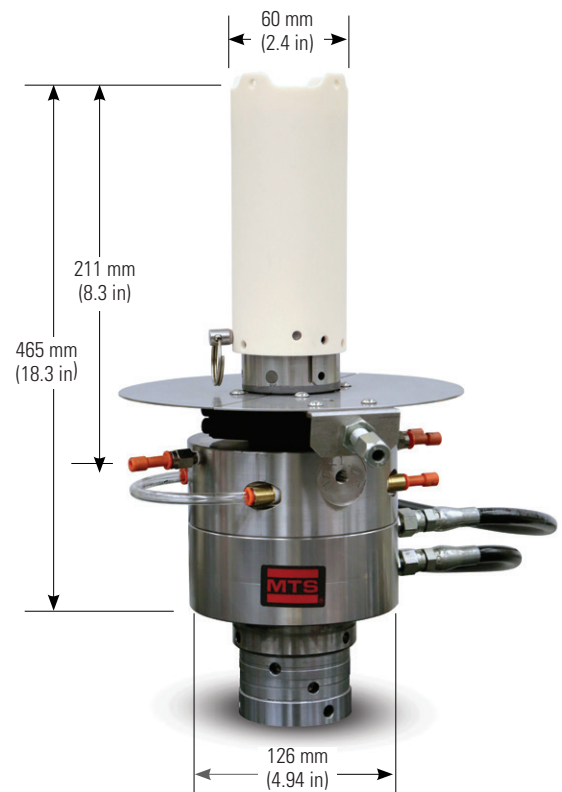

Button-Head End Round Specimens

Specimen Dimensions	Minimum	Maximum
A Overall Length	121 mm (4.75 in)	152 mm (6 in) *Recommended max.
B Maximum Button-Head Diameter*	–	20 mm (0.8 in)
C Maximum Button-Head Thickness	–	≤ 13.0 mm (0.51 in)
D Minimum Shank Length**	> 36.3 mm (1.43 in)	–
F Typical Gage Length	12.5 mm (0.5 in)	25 mm (1 in)

* It is recommended to follow ASTM E606 for details on LCF specimen dimensions.

** Shank length depends on overall specimen dimensions and furnace hot zone dimensions.

Button-Head Inserts

Shank Diameter "G"	Part Number
9.53 mm (0.375 in)	585805-01
10 mm (0.394 in)	585805-02
12 mm (0.472 in)	585805-03
12.70 mm (0.500 in)	585805-04

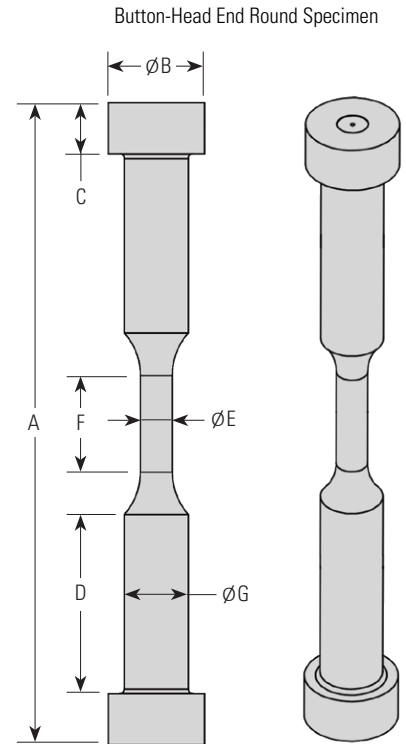

Threaded End Round Specimens

Specimen Dimensions	Minimum	Maximum
A Overall Length	76 mm (3 in)	152 mm (6 in) *Recommended max.
F Typical Gage Length	12.5 mm (0.5 in)	25 mm (1 in)

Threaded Inserts

Thread "B"	Thread Specimen Length "C"	Specimen Length "D"	Part Number
1/4-20 UNC-2B	> 14.76 mm (.581 in)	> 27.46 mm (1.081 in)	585806-01
1/4-28 UNF-2B	> 14.76 mm (.581 in)	> 27.46 mm (1.081 in)	585806-02
1/2-13 UNC-2B	> 27.46 mm (1.081 in)	> 40.16 mm (1.581 in)	585806-03
1/2-20 UNF-2B	> 27.46 mm (1.081 in)	> 40.16 mm (1.581 in)	585806-04
M6 X 1.00 - 6H	> 14.76 mm (.581 in)	> 27.46 mm (1.081 in)	585806-05
M12 X 1.25 - 6H	> 26.29 mm (1.035 in)	> 38.99 mm (1.535 in)	585806-06
M12 X 1.75 - 6H	> 26.29 mm (1.035 in)	> 38.99 mm (1.535 in)	585806-07
M16 X 2.00 - 6H	> 26.29 mm (1.035 in)	> 38.99 mm (1.535 in)	585806-08
M16 X 1.00 - 6H	> 26.29 mm (1.035 in)	> 38.99 mm (1.535 in)	585806-09
M14 X 1.00 - 6H	> 26.29 mm (1.035 in)	> 38.99 mm (1.535 in)	585806-10

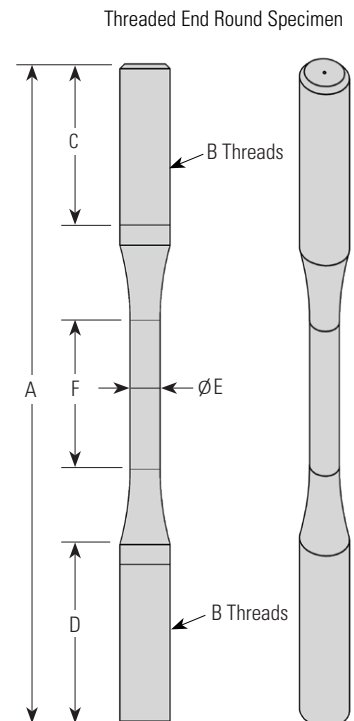

Regional Business Centers

THE AMERICAS

MTS Systems Corporation

14000 Technology Drive
Eden Prairie, MN 55344-2290
USA
Telephone: 952-937-4000
Toll Free: 800-328-2255
E-mail: info@mts.com
Internet: www.mts.com

EUROPE

MTS Systems France

BAT EXA 16
16/18 rue Eugène Dupuis
94046 Créteil Cedex
France
Telephone: +33-(0)1-58 43 90 00
E-mail: contact.france@mts.com

MTS Systems (Germany) GmbH

Hohentwielsteig 3
14163 Berlin
Germany
Telephone: +49-(0)30 81002-0
E-mail: euroinfo@mts.com

MTS Systems S.R.L. a socio unico

Strada Pianezza 289
10151 Torino
Italy
Telephone: +39-(0)11 45175 11 sel. pass.
E-mail: mtstorino@mts.com

MTS Systems Norden AB

Datavägen 37b
SE-436 32 Askim
Sweden
Telephone: +46-(0)31-68 69 99
E-mail: norden@mts.com

MTS Systems Limited

98 Church Street,
Hunslet,
Leeds
LS102AZ
United Kingdom
Telephone: +44 (0) 113 270 8011
E-mail: mtsksales@mts.com

ASIA/PACIFIC

MTS Japan Ltd.

Raiden Bldg. 3F 3-22-6,
Ryogoku, Sumida-ku,
Tokyo 130- 0026
Japan
Telephone: +81 3 5638 0850
E-mail: mts-j-info@mts.com

MTS Korea, Inc.

2nd F, Bundang Yemiji Building, 31,
Hwangsaeul-ro 258beon-gil,
Bundang-gu, Seongnam-si,
Gyeonggi-do, 13595
Korea
Telephone: +82-31-728-1600
E-mail: mtsk-info@mts.com

MTS Systems (China) Co., Ltd.

Floor 34, Building B,
New Caohejing International
Business Center,
No.391, Guiping Road,
Xuhui District
Shanghai 200233
P.R.China
Telephone: +021-24151000
Market: +021-24151111
Sales: +021-24151188
Service: +021-24151198
E-mail: MTSC-Info@mts.com

MTS Testing Solutions Pvt Ltd.

Unit No. 201 & 202, Second Floor
Donata Radiance,
Krishna Nagar Industrial Layout,
Koramangala, Bangalore - 560029
Karnataka, India
Telephone: + 91 80 46254100
Email: mts.india@mts.com



MTS Systems Corporation
14000 Technology Drive
Eden Prairie, MN 55344-2290 USA

ISO 9001 Certified QMS
<http://www.mts.com>

Specifications subject to change without notice.

MTS and Landmark is a registered trademark of MTS Systems Corporation in the United States. This trademark may be protected in other countries. RTM No. 211177.

©2025 MTS Systems Corporation
100-698-365b 680HiTempGrips • Printed in U.S.A. • 08/25