

Series 244 Hydraulic Actuators

Superior fidelity in force generation and motion control

be certain.

THE EVOLVING NEEDS OF MECHANICAL TESTING: TO TEST FASTER,
WITH HIGHER LOADS, GREATER FIDELITY AND INCREASED UPTIME,
HAVE PUT TOUGHER DEMANDS ON ACTUATORS. TO MEET THESE NEW
REQUIREMENTS, THE NEXT GENERATION OF MTS ACTUATION IS LONGER
LASTING AND MORE PRECISE THAN EVER BEFORE.



High-quality Actuators for Testing Applications

MTS actuators are optimized to meet the unique precision and dependability requirements of testing. Our engineers use proprietary materials and processes to minimize friction, helping to maximize reliability, wear resistance and energy efficiency. That's why MTS Series 244 Actuators are used worldwide in a variety of demanding applications from vehicle dynamics and structural fatigue to component testing, and are recommended for dynamic, static and fatigue applications.

3

Long Performance Life

MTS Series 244 Actuators are manufactured with an environmentally friendly, RoHS-compliant, rod surface coating and proprietary surface-finishing processes that set the industry standard for durability, longevity and performance. The rod treatment increases actuator life expectancy by 10x over actuators with conventionally chrome-plated rods.

Testing Speed & Fidelity

The rod coating reduces rod banding by 10x as well. Without having to adjust for rod banding, test engineers can keep the optimal zero stroke position and decrease the need for crosshead position changes that can disturb load train alignment. The ability to retain the zero stroke position over hundreds of millions of punishing cycles, will give more consistent testing results and speed the testing process. In addition, higher fidelity actuators reduce the distortion that can lead to measurement uncertainty and save time by producing statistically significant results in fewer batches.

Energy Efficiency

MTS actuators are engineered to provide maximum performance while introducing the minimal amount of friction into the test system, reducing internal flow losses and heat produced, thus requiring less energy to operate. Minimizing drain flow eliminates the need to use scavenge pumps that negatively aerate oil, further reducing the required energy budget. When these actuators are used with other energy-saving MTS hydraulic products, the cost savings multiply.

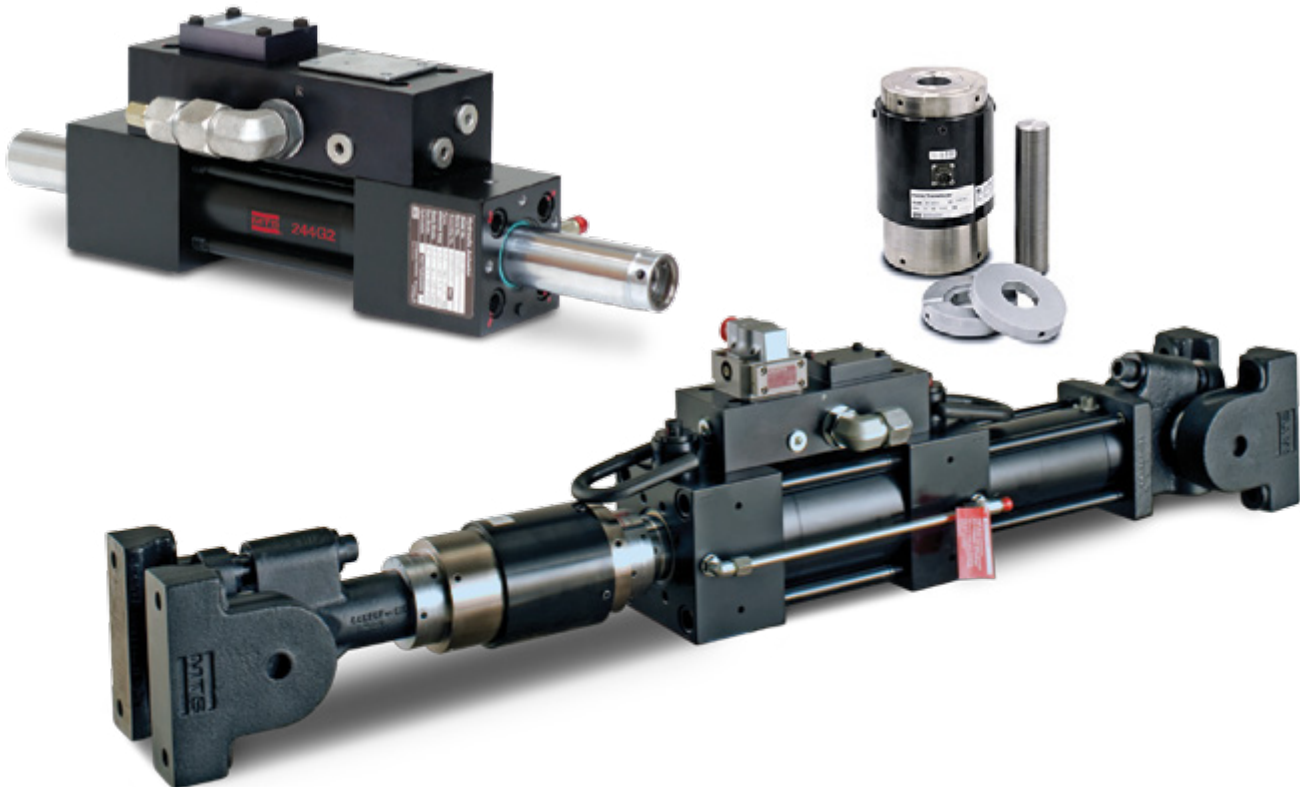

Built to Last

MTS Series 244 Actuators are double-ended, fatigue-rated and designed with proprietary materials that minimize friction, while maximizing reliability, wear resistance and ease of maintenance. They are hydraulically-powered pistons that can extend or retract (double-acting) to provide displacement or force into a test article or structure.

Difference in the Details

Advanced design characteristics make MTS hydraulic actuators the preferred choice for dynamic force generation around the world. MTS thermal spray-coated rods increase rod service life by 10x over hard chrome-plated rods.

A piston rod end with replaceable,

hardened-steel insert allows you to quickly replace damaged threads and switch between metric and US customary components.

An **integral bonded bearing design** bonds high-capacity polymer piston rod bearings directly to the end cap, providing high side load tolerance and excellent resistance to galling and seizure. Optional hydrostatic pressure-centering bearings can support continuous high-speed operation under heavy side loads.

Large ports accept servovalve flow rates up to 340 lpm (90 gpm), and a **variety of servovalve mounting options** let you configure precisely the performance level you want.

A **one-piece, double-ended piston rod design** eliminates compromises caused by unequal tension and compression piston areas. MTS thermal spray-coated rods increase rod service life by 10x over conventional hard chrome-plated rods.

A **reinforced PTFE piston seal** provides a positive seal and reduces friction.

Upper and lower hydraulic cushions safeguard the actuator from accidental high-velocity impacts between the piston and end cap.

Proprietary MTS rod seals provide long life, low friction and exceptional performance in high-frequency, low-displacement applications.

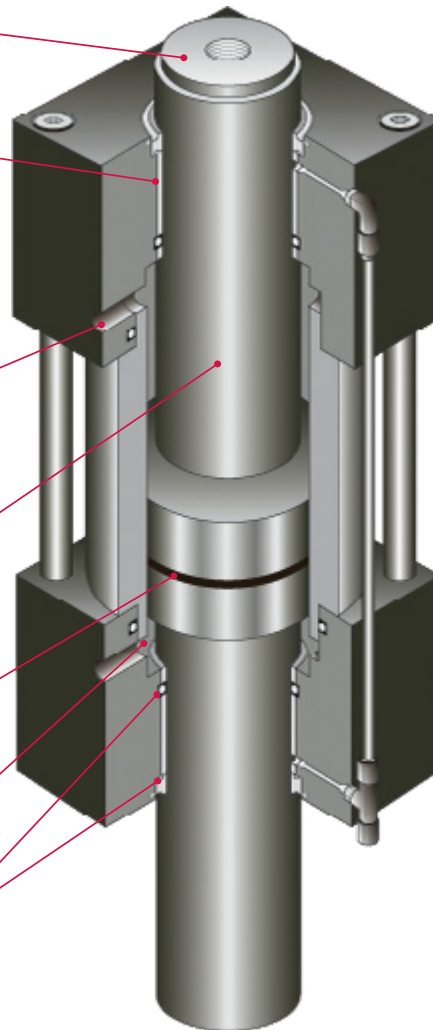

KEY FEATURES

- » Thermal spray-coated piston rods that have 10x greater service life than hard chrome-plated rods
- » Proprietary MTS seal and bearing designs and surface-coating processes set the industry standard for durability, longevity and performance
- » Double-ended, fatigue-rated design (piston rod extends from both sides) combines balanced dynamic performance and robust side-load tolerance to maximize data fidelity
- » Full-stroke, coaxially-mounted displacement transducer
- » High-capacity, non-metallic, ultra-low friction bearings bonded directly to the end caps offer high side-load tolerance and resistance to failure from galling and seizure
- » Cushions protect the actuator from the effects of high-speed and high-mass forces, and prevent the piston from contacting the end caps

Durable Components

Choose from a full assortment of complementary products and components for use with your MTS hydraulic actuators. All these options are engineered to improve the quality and repeatability of your test results.

LINEAR VARIABLE DIFFERENTIAL TRANSFORMERS

MTS 244G2 actuators come with standard LVDTs. Manufactured to strict MTS specifications, these LVDTs produce an analog signal with excellent linearity.

TEMPOSONICS® LINEAR SENSORS

These sensors use the time-based magnetostrictive position sensing principle developed by MTS and are offered as a standard option. Non-contact sensing reduces wear and increases durability and output repeatability. Tempsonics displacement achieves ASTM E2309 Class A performance accuracy.

FORCE TRANSDUCERS

Highly accurate MTS force transducers feature a low-profile design for easy system integration.

MOUNTING ACCESSORIES

Choose from a variety of mounting methods, including pedestal, clevis and swivel.

SWIVEL ROD ENDS

This spherical bearing features a patented adjustable preload mechanism to minimize backlash.

SPIRAL WASHERS

These accessories create a backlash-free assembly by fully preloading the connections between actuator, mounting and force transducer.

SERVOVALVES

Precision-engineered MTS servovalves deliver high-flow, quick-response and low-distortion performance to uphold the fidelity of your test data.

PEDESTAL BASE ACTUATOR

Although most applications profit from at least a small degree of pivotal freedom, others require rigid actuator fixturing. Pedestal bases are available for all actuator models to handle these situations. Vibration testing, seismic tables, and horizontal cantilever installations are common applications for pedestal bases. Check with your sales representative for help in determining the effect of sideloads on pedestal base installations.

CLOSE-COUPLED ACCUMULATORS

Accumulators provide the stored energy required to meet peak flow demand in a timely manner.

HYDRAULIC SERVICE MANIFOLDS (HSMs)

MTS HSMs reliably control the distribution of hydraulic flow to test stations.

HYDRAULIC POWER UNITS (HPUs)

MTS SilentFlo™ HPUs provide clean, quiet and energy-efficient hydraulic power supply. They are also extremely compact, so they can be deployed directly in the test lab, without the need for special pump housing facilities.

FROM THE LEADING GLOBAL PROVIDER OF TESTING SOLUTIONS, SERVICE AND SUPPORT

MTS is recognized worldwide for helping people build confidence in the performance of their products. Our high-performance hydraulic actuators play a central role in helping test professionals achieve the highest levels of certainty.

We also field one of the largest, most experienced global service, support and consulting staff of any testing solution provider. Our complete lifecycle management services portfolio can help you maximize your productivity and uptime, while getting the longest functional life possible from your MTS investments.

Since our company's very beginning, we have also been deeply involved in the engineering, fabrication and installation of hydraulic distribution systems for customers worldwide. We can apply sound engineering practices at all stages of design and integration, to provide you with the optimal hydraulic distribution system for your test lab.



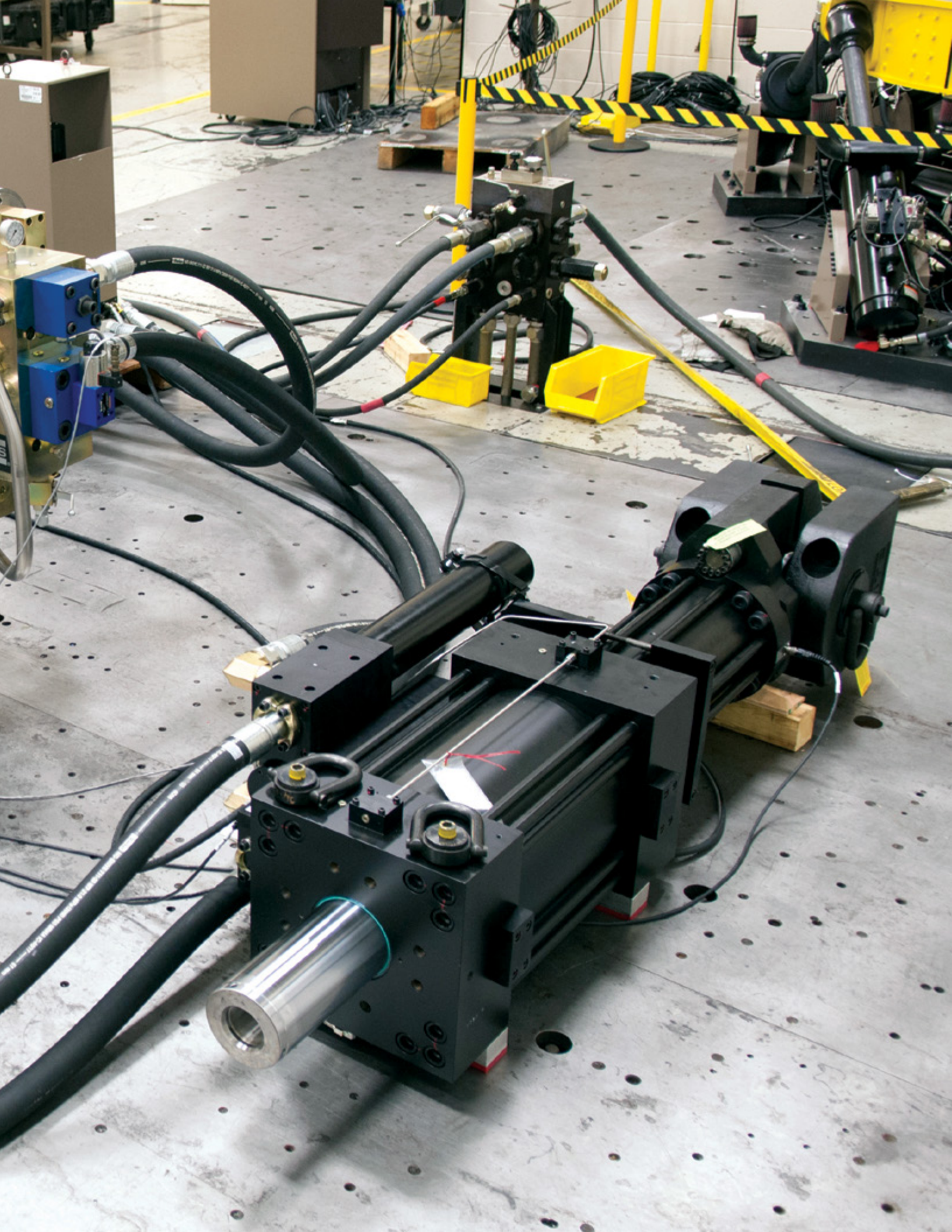

More Standard Sizes

These actuators come in a greater variety of standard stroke lengths to meet a wider range of fixturing dimensions. They are available from 100 – 500 mm (4 – 20 inches, in 2-inch increments) and with force ratings from 15 – 1000 kN (3.3 – 220 kip).

Each Series 244 Actuator is available in these standard stroke lengths:

Stroke Length	
mm	inch
100	4
150	6
200	8
250	10
300	12
350	14
400	16
450	18
500	20

7

244 Actuator Specifications

Model	Force Rating		Rod Threads		Hydraulic Connection
	KN	lbs	Metric	US Customary	
244.11	15	3,300	M12x1.25	1/2"-20	Pressure & Return – Pressure and return line connections depend on the servovalve. Configurations with Series 252 Servovalve Manifolds have SAE -16 fittings. Series 256 Servovalve Manifolds have SAE -20 fittings. Drain – All 244 Actuators have a SAE -6 drain connection.
244.12	25	5,500	M12x1.25	1/2"-20	
244.21	50	11,000	M27x2	1"-14	
244.20	67	15,000	M27x2	1"-14	
244.22	100	22,000	M27x2	1"-14	
244.23	150	35,000	M27x2	1"-14	
244.31	250	55,000	M36x2	1 1/2"-12	
244.41	500	110,000	M52x2	2"-12	
244.51	1000	220,000	M76x2	3"-12	

Specifications subject to change without notice. Please contact MTS for specifications critical to your application.

Typical Configurations for Component or Structural Testing Applications

Model	Servovalve	Load Cell	Swivel	Spiral Washers
244.11	252.2X (qty 1 or 2)	661.19E/F-03	249xx.M25	601.11-20
244.12	252.2X (qty 1 or 2)	661.19E/F-04	249xx.M25	601.11-20
244.21	252.2X (qty 1 or 2)	661.20E/F-02	249xx.M70	601.11-11
244.20	252.2X (qty 1 or 2)	661.20E/F-03	249xx.M70	601.11-11
244.22	252.2X (qty 1 or 2)	661.20E/F-03	249xx.M160	601.11-11
244.23	252.2X (qty 1 or 2)	661.22C/D-01	249xx.M160	601.11-11
244.31	252.2X (qty 1 or 2), 256 (qty 1)	661.22C/D-01	249xx.M340	601.11-19
244.41	252.2X (qty 1 or 2), 256 (qty 1)	661.23E/F-01	249xx.M500	601.11-13
244.51	252.2X (qty 1 or 2), 256 (qty 1)	661.31E/F-01	249xx.M1000	601.11-15

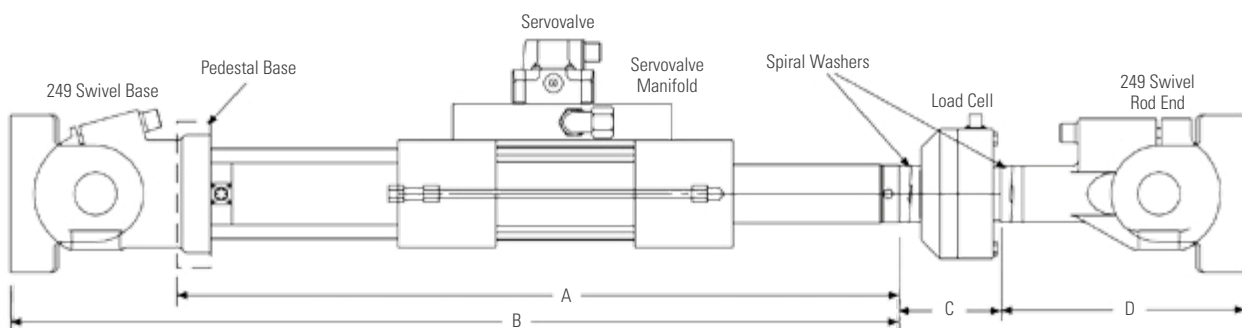

244 Actuator Assembly Dimensions										
Model	Stroke		Length with Pedestal Base **(A)		Length with Swivel Base **(B)		Load Cell **(C)		Rod End Swivel **(D)	
	mm	in	mm	in	mm	in	mm	in	mm	in
244.11	100	4	652	25.66	741	29.16	87.6	3.45	141.7	5.58
	150	6	779	30.66	868	34.16	87.6	3.45	141.7	5.58
	200	8	906	35.66	995	39.16	87.6	3.45	141.7	5.58
	250	10	1033	40.66	1122	44.16	87.6	3.45	141.7	5.58
	300	12	1160	45.66	1249	49.16	87.6	3.45	141.7	5.58
	350	14	1287	50.66	1376	54.16	87.6	3.45	141.7	5.58
	400	16	1414	55.66	1503	59.16	87.6	3.45	141.7	5.58
	450	18	1541	60.66	1630	64.16	87.6	3.45	141.7	5.58
	500	20	1668	65.66	1757	69.16	87.6	3.45	141.7	5.58
	244.12	100	4	652	25.66	741	29.16	87.6	3.45	141.7
150		6	779	30.66	868	34.16	87.6	3.45	141.7	5.58
200		8	906	35.66	995	39.16	87.6	3.45	141.7	5.58
250		10	1033	40.66	1122	44.16	87.6	3.45	141.7	5.58
300		12	1160	45.66	1249	49.16	87.6	3.45	141.7	5.58
350		14	1287	50.66	1376	54.16	87.6	3.45	141.7	5.58
400		16	1414	55.66	1503	59.16	87.6	3.45	141.7	5.58
450		18	1541	60.66	1630	64.16	87.6	3.45	141.7	5.58
500		20	1668	65.66	1757	69.16	87.6	3.45	141.7	5.58
244.21		100	4	650	25.61	787	30.98	121.4	4.78	224.3
	150	6	777	30.61	914	35.98	121.4	4.78	224.3	8.83
	200	8	904	35.61	1041	40.98	121.4	4.78	224.3	8.83
	250	10	1031	40.61	1168	45.98	121.4	4.78	224.3	8.83
	300	12	1158	45.61	1295	50.98	121.4	4.78	224.3	8.83
	350	14	1285	50.61	1422	55.98	121.4	4.78	224.3	8.83
	400	16	1412	55.61	1549	60.98	121.4	4.78	224.3	8.83
	450	18	1539	60.61	1676	65.98	121.4	4.78	224.3	8.83
	500	20	1666	65.61	1803	70.98	121.4	4.78	224.3	8.83
	244.20	100	4	650	25.61	787	30.98	121.4	4.78	224.3
150		6	777	30.61	914	35.98	121.4	4.78	224.3	8.83
200		8	904	35.61	1041	40.98	121.4	4.78	224.3	8.83
250		10	1031	40.61	1168	45.98	121.4	4.78	224.3	8.83
300		12	1158	45.61	1295	50.98	121.4	4.78	224.3	8.83
350		14	1285	50.61	1422	55.98	121.4	4.78	224.3	8.83
400		16	1412	55.61	1549	60.98	121.4	4.78	224.3	8.83
450		18	1539	60.61	1676	65.98	121.4	4.78	224.3	8.83
500		20	1666	65.61	1803	70.98	121.4	4.78	224.3	8.83
244.22		100	4	635	25.00	829	32.64	121.4	4.78	289.8
	150	6	762	30.00	956	37.64	121.4	4.78	289.8	11.41
	200	8	889	35.00	1083	42.64	121.4	4.78	289.8	11.41
	250	10	1016	40.00	1210	47.64	121.4	4.78	289.8	11.41
	300	12	1143	45.00	1337	52.64	121.4	4.78	289.8	11.41
	350	14	1270	50.00	1464	57.64	121.4	4.78	289.8	11.41
	400	16	1397	55.00	1591	62.64	121.4	4.78	289.8	11.41
	450	18	1524	60.00	1718	67.64	121.4	4.78	289.8	11.41
	500	20	1651	65.00	1845	72.64	121.4	4.78	289.8	11.41

(continued...)

(continued)

244 Actuator Assembly Dimensions										
Model	Stroke		Length with Pedestal Base **(A)		Length with Swivel Base **(B)		Load Cell **(C)		Rod End Swivel **(D)	
	mm	in	mm	in	mm	in	mm	in	mm	in
244.23	100	4	634	24.96	828	32.59	229.4	9.03	289.8	11.41
	150	6	761	29.96	955	37.59	229.4	9.03	289.8	11.41
	200	8	888	34.96	1082	42.59	229.4	9.03	289.8	11.41
	250	10	1015	39.96	1209	47.59	229.4	9.03	289.8	11.41
	300	12	1142	44.96	1336	52.59	229.4	9.03	289.8	11.41
	350	14	1269	49.96	1463	57.59	229.4	9.03	289.8	11.41
	400	16	1396	54.96	1590	62.59	229.4	9.03	289.8	11.41
	450	18	1523	59.96	1717	67.59	229.4	9.03	289.8	11.41
	500	20	1650	64.96	1844	72.59	229.4	9.03	289.8	11.41
	244.31	100	4	664	26.16	918	36.16	235.0	9.25	387.4
150		6	791	31.16	1045	41.16	235.0	9.25	387.4	15.25
200		8	918	36.16	1172	46.16	235.0	9.25	387.4	15.25
250		10	1045	41.16	1299	51.16	235.0	9.25	387.4	15.25
300		12	1172	46.16	1426	56.16	235.0	9.25	387.4	15.25
350		14	1299	51.16	1553	61.16	235.0	9.25	387.4	15.25
400		16	1426	56.16	1680	66.16	235.0	9.25	387.4	15.25
450		18	1553	61.16	1807	71.16	235.0	9.25	387.4	15.25
500		20	1680	66.16	1934	76.16	235.0	9.25	387.4	15.25
244.41		100	4	707	27.85	1050	41.35	235.0	9.25	472.9
	150	6	834	32.85	1177	46.35	235.0	9.25	472.9	18.62
	200	8	961	37.85	1304	51.35	235.0	9.25	472.9	18.62
	250	10	1088	42.85	1431	56.35	235.0	9.25	472.9	18.62
	300	12	1215	47.85	1558	61.35	235.0	9.25	472.9	18.62
	350	14	1342	52.85	1685	66.35	235.0	9.25	472.9	18.62
	400	16	1469	57.85	1812	71.35	235.0	9.25	472.9	18.62
	450	18	1596	62.85	1939	76.35	235.0	9.25	472.9	18.62
	500	20	1723	67.85	2066	81.35	235.0	9.25	472.9	18.62
	244.51	100	4	733	28.87	1279	50.37	349.3	13.75	654.1
150		6	860	33.87	1406	55.37	349.3	13.75	654.1	25.75
200		8	987	38.87	1533	60.37	349.3	13.75	654.1	25.75
250		10	1114	43.87	1660	65.37	349.3	13.75	654.1	25.75
300		12	1241	48.87	1787	70.37	349.3	13.75	654.1	25.75
350		14	1368	53.87	1914	75.37	349.3	13.75	654.1	25.75
400		16	1495	58.87	2041	80.37	349.3	13.75	654.1	25.75
450		18	1622	63.87	2168	85.37	349.3	13.75	654.1	25.75
500		20	1749	68.87	2295	90.37	349.3	13.75	654.1	25.75

9

** Dimensions are lengths with the actuator positioned at mid-stroke.

*** Dimension includes spiral pre-load washers for actuators.

Specifications subject to change without notice.

Please contact MTS for specifications critical to your application.

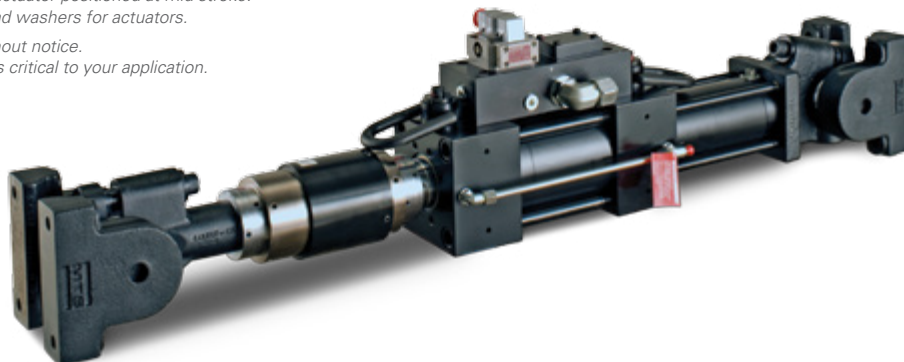

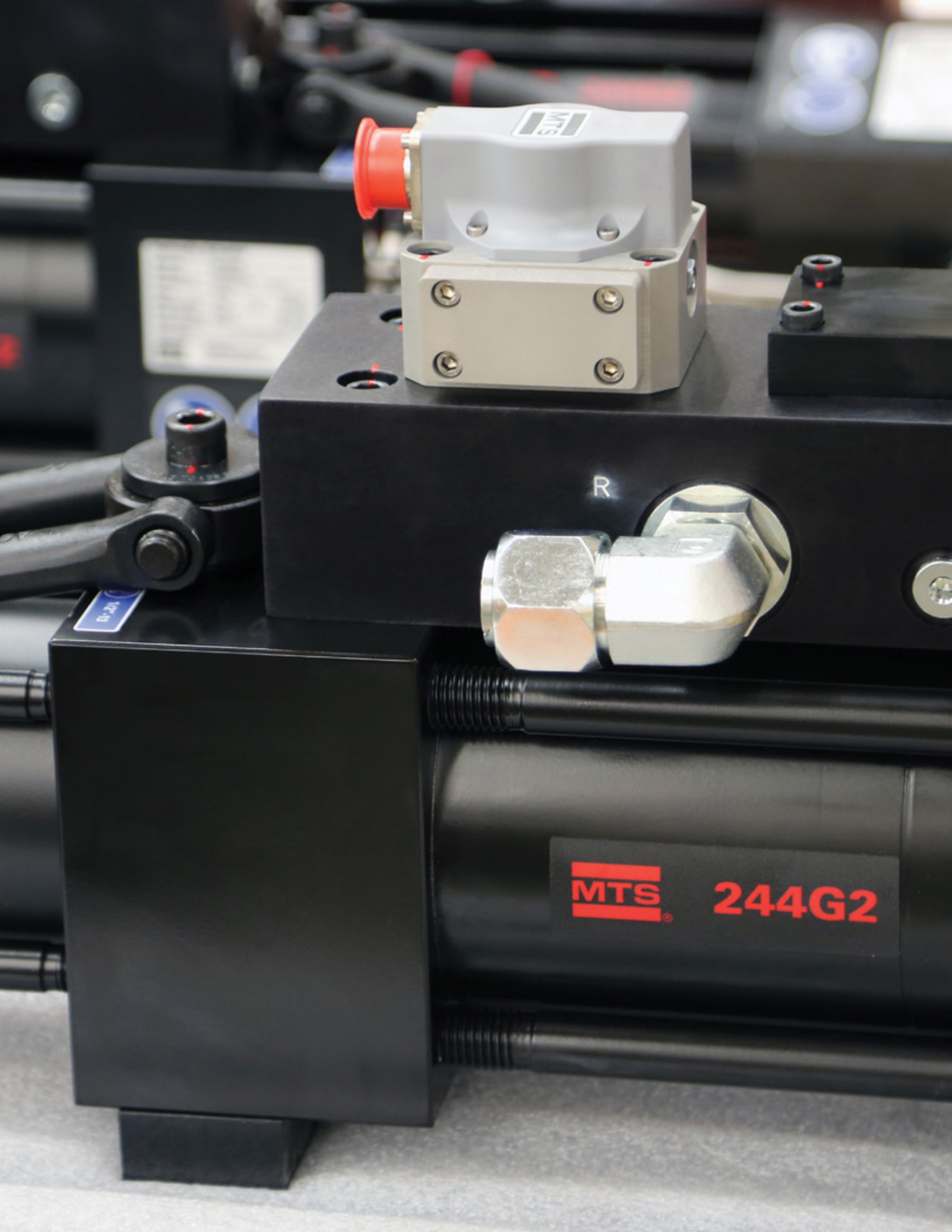

MTS

R

MTS 244G2

01-201

244 Actuator Capacity

A complete servoactuator assembly includes the actuator, servovalve, load cell, and swivels. The load cell and rod end swivel require attachment kits for connecting these components to the actuator. Servovalves, load cells, rod end swivels, and attachment kits for an actuator assembly are selected separately.

244Actuator

Capacity

- 244.11** 15kN (3,300 lbs)
- 244.12** 25 kN (5,500 lbs)
- 244.21** 50 kN (11,000 lbs)
- 244.20** 67 kN (15,000 lbs)
- 244.22** 100 kN (22,000 lbs)
- 244.23** 150 kN (35,000 lbs)
- 244.31** 250 kN (55,000 lbs)
- 244.41** 500 kN (110,000 lbs)
- 244.51** 1000 kN (220,000 lbs)

Displacement

- 100 mm (4 in)
- 150 mm (6 in)
- 200 mm (8 in)
- 250 mm (10 in)
- 300 mm (12 in)
- 350 mm (14 in)
- 400 mm (16 in)
- 450 mm (18 in)
- 500 mm (20 in)

Rod Thread

- Metric
- US Customary

Base

- 249 Swivel Base
- 249 Rod End Swivel
- Pedestal Base

Servovalve Manifold

- 252.2X Two Stage Servovalve Manifold *(does not include the valve)*
- 256.0X Three Stage Servovalve Manifold *(does not include the valve)*

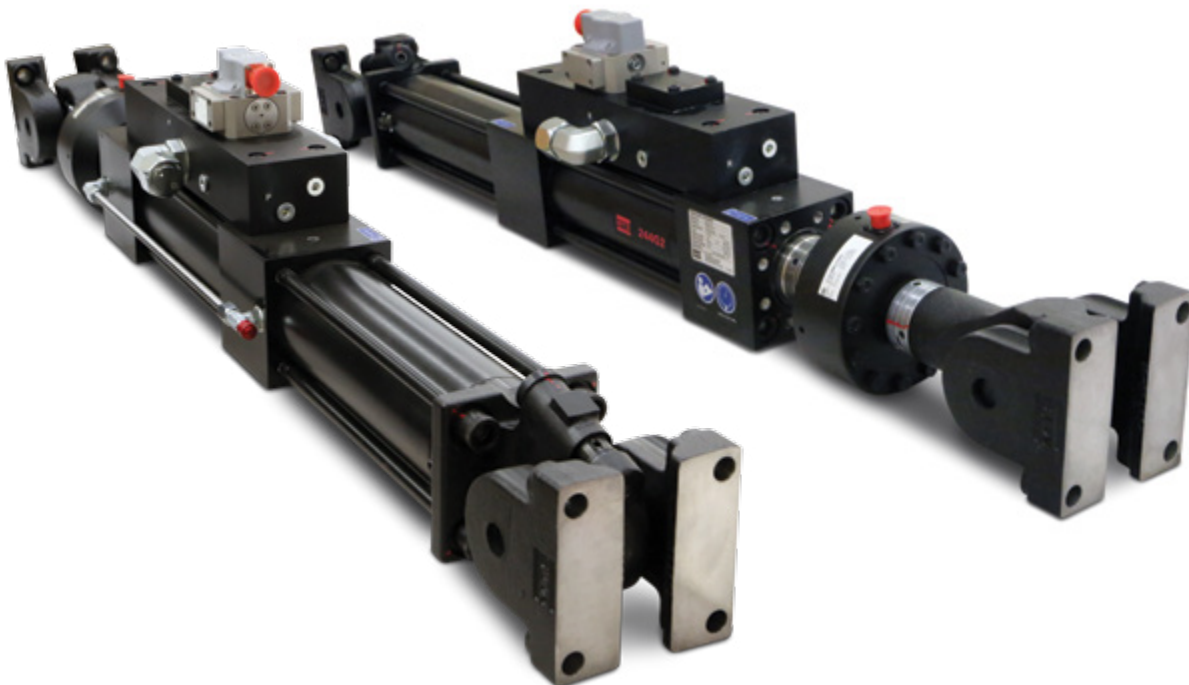

Regional Business Centers

THE AMERICAS

MTS Systems Corporation

14000 Technology Drive
Eden Prairie, MN 55344-2290

USA

Telephone: 952-937-4000
Toll Free: 800-328-2255
Fax: 952-937-4515
E-mail: info@mts.com
Internet: www.mts.com

EUROPE

MTS Systems France

BAT EXA 16
16/18 rue Eugène Dupuis
94046 Créteil Cedex

France

Telephone: +33-(0)1-58 43 90 00
Fax: +33-(0)1-58 43 90 01
E-mail: contact.france@mts.com

MTS Systems GmbH

Hohentwielsteig 3
14163 Berlin

Germany

Telephone: +49-(0)30 81002-0
Fax: +49-(0)30 81002-100
E-mail: euroinfo@mts.com

MTS Systems S.R.L. a socio unico

Strada Pianezza 289
10151 Torino

Italy

Telephone: +39-(0)11 45175 11 sel. pass.
Fax: +39-(0)11 45175 00-01
E-mail: mtstorino@mts.com

MTS Systems Norden AB

Datavägen 37b
SE-436 32 Askim
Sweden
Telephone: +46-(0)31-68 69 99
Fax: +46-(0)31-68 69 80
E-mail: norden@mts.com

MTS Systems Ltd. UK

40 Alan Turing Road
Surrey Research Park
Guildford
Surrey
GU2 7YF

United Kingdom

Telephone: +44-(0)1483-533731
Fax: +44-(0)1483-504564
E-mail: mtsuksales@mts.com

ASIA/PACIFIC

MTS Japan Ltd.

ArcaCentral Bldg. 8F
1-2-1 Kinshi, Sumida-ku
Tokyo 130-0013

Japan

Telephone: 81-3-6658-0901
Fax: 81-3-6658-0904
E-mail: mts-j-info@mts.com

MTS Korea, Inc.

4th F., ATEC Tower, 289,
Pankyo-ro, Bundang-gu
Seongnam-si

Gyeonggi-do 13488,

Korea

Telephone: 82-31-728-1600
Fax: 82-31-728-1699
E-mail: mts-k-info@mts.com

MTS China Hechuan Office

Room 703 Building #B,
Venture International Park,
No. 2679 Hechuan Road,
Minhang District,
Shanghai 201103,

P.R.China

Telephone: +86-21-5427 1122
Fax: +86-21-6495 6330
E-mail: info@mtschina.com



MTS Systems Corporation

14000 Technology Drive
Eden Prairie, MN 55344-2290 USA